

**Industrial Maintenance**

# **Ball Screws and Linear Bearings**

**Course Sample**

49350-3C

Order no.: 49350-3C  
First Edition  
Revision level: 03/2018

By the staff of Festo Didactic

© Festo Didactic Ltée/Ltd, Quebec, Canada 2018  
Internet: [www.festo-didactic.com](http://www.festo-didactic.com)  
e-mail: [did@de.festo.com](mailto:did@de.festo.com)

Printed in Canada  
All rights reserved  
ISBN 978-2-89789-175-6 (Printed version)  
ISBN 978-2-89789-177-0 (CD-ROM)  
Legal Deposit – Bibliothèque et Archives nationales du Québec, 2018  
Legal Deposit – Library and Archives Canada, 2018

The purchaser shall receive a single right of use which is non-exclusive, non-time-limited and limited geographically to use at the purchaser's site/location as follows.

The purchaser shall be entitled to use the work to train his/her staff at the purchaser's site/location and shall also be entitled to use parts of the copyright material as the basis for the production of his/her own training documentation for the training of his/her staff at the purchaser's site/location with acknowledgement of source and to make copies for this purpose. In the case of schools/technical colleges, training centers, and universities, the right of use shall also include use by school and college students and trainees at the purchaser's site/location for teaching purposes.

The right of use shall in all cases exclude the right to publish the copyright material or to make this available for use on intranet, Internet, and LMS platforms and databases such as Moodle, which allow access by a wide variety of users, including those outside of the purchaser's site/location.

Entitlement to other rights relating to reproductions, copies, adaptations, translations, microfilming, and transfer to and storage and processing in electronic systems, no matter whether in whole or in part, shall require the prior consent of Festo Didactic.

















Information in this document is subject to change without notice and does not represent a commitment on the part of Festo Didactic. The Festo materials described in this document are furnished under a license agreement or a nondisclosure agreement.

Festo Didactic recognizes product names as trademarks or registered trademarks of their respective holders.











All other trademarks are the property of their respective owners. Other trademarks and trade names may be used in this document to refer to either the entity claiming the marks and names or their products. Festo Didactic disclaims any proprietary interest in trademarks and trade names other than its own.

# Safety and Common Symbols

The following safety and common symbols may be used in this manual and on the equipment:

Symbol	Description
	<b>DANGER</b> indicates a hazard with a high level of risk which, if not avoided, will result in death or serious injury.
	<b>WARNING</b> indicates a hazard with a medium level of risk which, if not avoided, could result in death or serious injury.
	<b>CAUTION</b> indicates a hazard with a low level of risk which, if not avoided, could result in minor or moderate injury.
	<b>CAUTION</b> used without the <i>Caution, risk of danger</i> sign  , indicates a hazard with a potentially hazardous situation which, if not avoided, may result in property damage.
	Caution, risk of electric shock
	Caution, hot surface
	Caution, risk of danger. Consult the relevant user documentation.
	Caution, lifting hazard
	Caution, belt drive entanglement hazard
	Caution, chain drive entanglement hazard
	Caution, gear entanglement hazard
	Caution, hand crushing hazard
	Notice, non-ionizing radiation
	Consult the relevant user documentation.
	Direct current
	Alternating current

# Safety and Common Symbols

Symbol	Description
	Both direct and alternating current
	Three-phase alternating current
	Earth (ground) terminal
	Protective conductor terminal
	Frame or chassis terminal
	Equipotentiality
	On (supply)
	Off (supply)
	Equipment protected throughout by double insulation or reinforced insulation
	In position of a bi-stable push control
	Out position of a bi-stable push control

# Table of Contents

Preface .....	VII
About This Manual .....	IX
To the Instructor .....	XI
<b>Job Sheet 1    Linear Bearings .....</b>	<b>1</b>
<b>Job Sheet 2    Ball Nuts and Ball Screws .....</b>	<b>15</b>
<b>Job Sheet 3    Backlash .....</b>	<b>33</b>
<b>Job Sheet 4    Pitch, Lead, Start, and Speed.....</b>	<b>43</b>
<b>Appendix A    Equipment Utilization Chart.....</b>	<b>51</b>
<b>Appendix B    Lockout/Tagout Procedure .....</b>	<b>53</b>
<b>Appendix C    Post-Test.....</b>	<b>55</b>



# Preface

The Mechanical Drives Training System covers the installation, use, maintenance, and troubleshooting of mechanical drives.

The curriculum is divided into levels and covers the following topics:

- Introduction to mechanical drive systems
- Belt drives
- Chain drives
- Gear drives
- Shaft alignment and couplings
- Bearings and seals
- Ball screws and linear bearings
- Clutches and brakes
- Vibration metering
- Vibration analysis
- Notions of lubrication

The figure below shows the available course material for the Mechanical Drives Training System.

# Preface

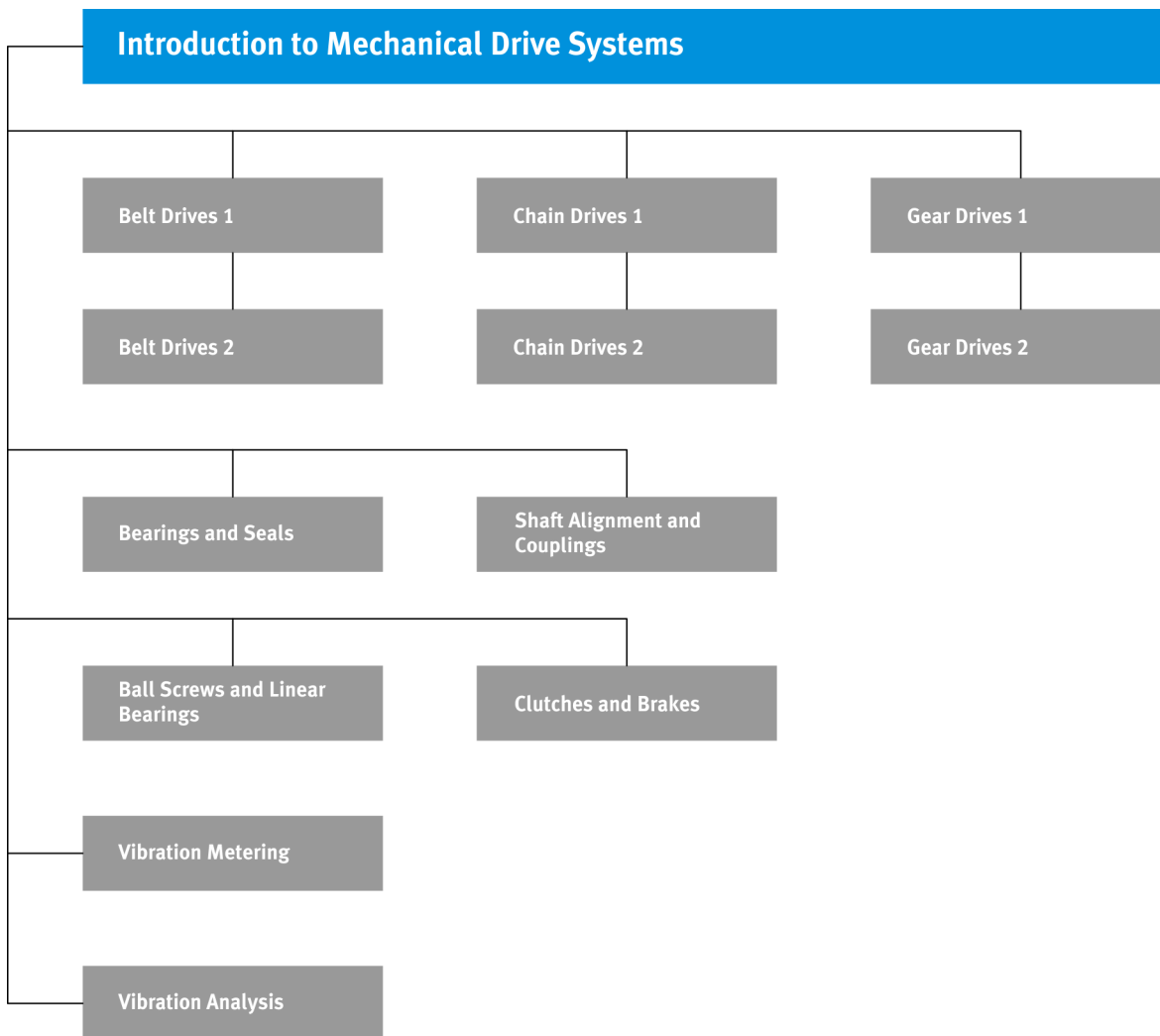

**Mechanical Drives Training System course material.**

We invite readers of this manual to send us their tips, feedback, and suggestions for improving the book.

Please send these to [did@de.festo.com](mailto:did@de.festo.com).

The authors and Festo Didactic look forward to your comments.



# About This Manual

The Ball Screws and Linear Bearings manual introduces the basics of ball screws and linear bearings.

The topics covered in this manual are presented in the form of job sheets. The job sheets include a description of the objectives, a list of equipment required, safety procedures, and a list of steps required to attain the objectives.

The topics are usually introduced in an information job sheet. However, to obtain detailed information about the covered topic, you should refer to your textbook or ask your instructor to guide your learning process.

The job sheets follow a logical sequence which allows you to assimilate the concepts efficiently. The job sheets should be performed one after another since the content of a given job sheet builds on the knowledge acquired in the previous one.

## **Manual objectives**

When you have completed this manual, you will be familiar with ball screws and linear ball bearings. You will know how to install them and how they are used in linear guide assemblies. You will have learned what backlash is, in regard to ball screws, and how to minimize or eliminate it. You will have studied the pitch, lead, and start of a ball screw, and know how to determine and calculate these parameters. You will be familiar with the relationship between the pitch, lead, and start of a ball screw, as well as their effects on the ball screw speed. You will have studied the main elements required for the lubrication and maintenance of linear bearings and ball screws.

## **Safety considerations**

Safety symbols that may be used in this manual and on the equipment are listed in the Safety and Common Symbols table at the beginning of the manual.

Safety procedures related to the tasks that you will be asked to perform are indicated in each exercise.

Make sure that you are wearing appropriate protective equipment when performing the tasks. You should never perform a task if you have any reason to think that a manipulation could be dangerous for you or your teammates.

## **Prerequisite**

As a prerequisite to this course, you should have read the manual titled *Introduction to Mechanical Drive Systems*.

## **Systems of units**

Units are expressed using the International System of Units (SI).

# About This Manual

## **Appendices**

The appendices included in this manual are:

- Appendix A: Equipment Utilization Chart, indicates the equipment used in the job sheets.
- Appendix B: Lockout/Tagout Procedure, describes the lockout/tagout procedure that must be performed at the beginning of all job sheets.
- Appendix C: Post-Test, evaluates the knowledge of the topics covered in the job sheets.

# To the Instructor

You will find in this Instructor Guide all the elements included in the Student Manual together with the answers to all questions, results of measurements, graphs, explanations, suggestions, and, in some cases, instructions to help you guide the students through their learning process. All the information that applies to you is placed between markers and appears in red.

## **Accuracy of measurements**

The numerical results of the hands-on exercises may differ from one student to another. For this reason, the results and answers given in this manual should be considered as a guide. Students who correctly performed the exercises should expect to demonstrate the principles involved and make observations and measurements similar to those given as answers.

Before a student begins a job sheet, ensure that the equipment is in good condition and does not represent any risk when used.

When a student must complete a setup that is already partially mounted, ensure that the setup corresponds to the job description.

When the jobs are performed in teams, ensure that each student has and installs a padlock when performing the Lockout/Tagout procedure.



Sample  
Extracted from  
Job Sheets - Instructor



## Ball Nuts and Ball Screws

Ball screws are force and motion transfer devices that convert rotary motion to linear motion, or torque to thrust, and vice versa. They consist of a screw with a precision helical groove (the inner race), a nut with an internal groove (the outer race), and precision steel balls that circulate in the grooves between the screw and nut. Figure 15 shows a typical ball screw and nut.

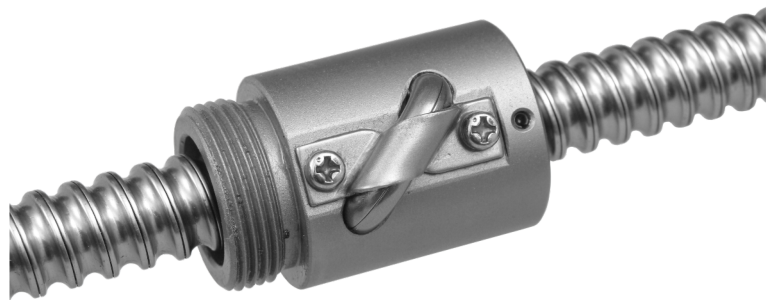

Figure 15. Ball screw and nut.

The balls are diverted from one end of the nut and carried through a return circuit to the opposite end, as shown in Figure 16. The return circuit is typically a pipe outside the ball nut, but can also be a deflector or a through hole in the nut. Some free space is present in the ball circuit to prevent the balls from skidding. During operation, either the screw or the nut rotates, while the other component moves linearly.

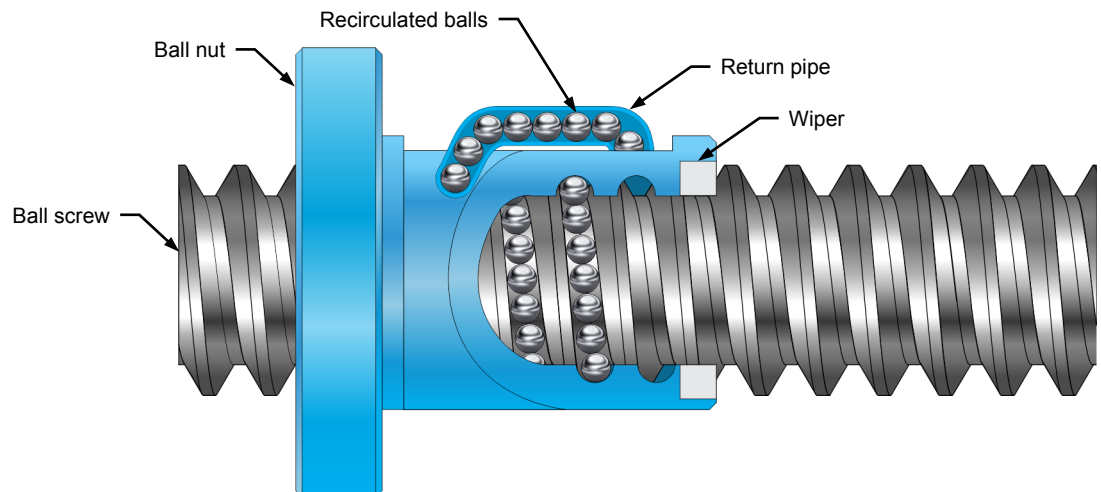

Figure 16. Side view of a ball screw.

In a ball screw and nut combination, the balls between the nut and the screw roll with very little friction. In a conventional nut and machine screw combination, the friction is much higher since the threaded faces slide on one another. Because of this, ball screw and nut combinations have a very high efficiency in comparison to other mechanisms that convert rotary motion to linear motion.

Axial loads are parallel to the ball screw, while radial loads are perpendicular to it.

Ball screws are designed for axial loads, also called thrust loads. They can tolerate both compression and tensile axial loads, as shown in Figure 17a and b. However, ball screws are not designed for radial loads, or side loads, as shown in Figure 17c. Applying radial loads on a ball screw could significantly reduce its life.

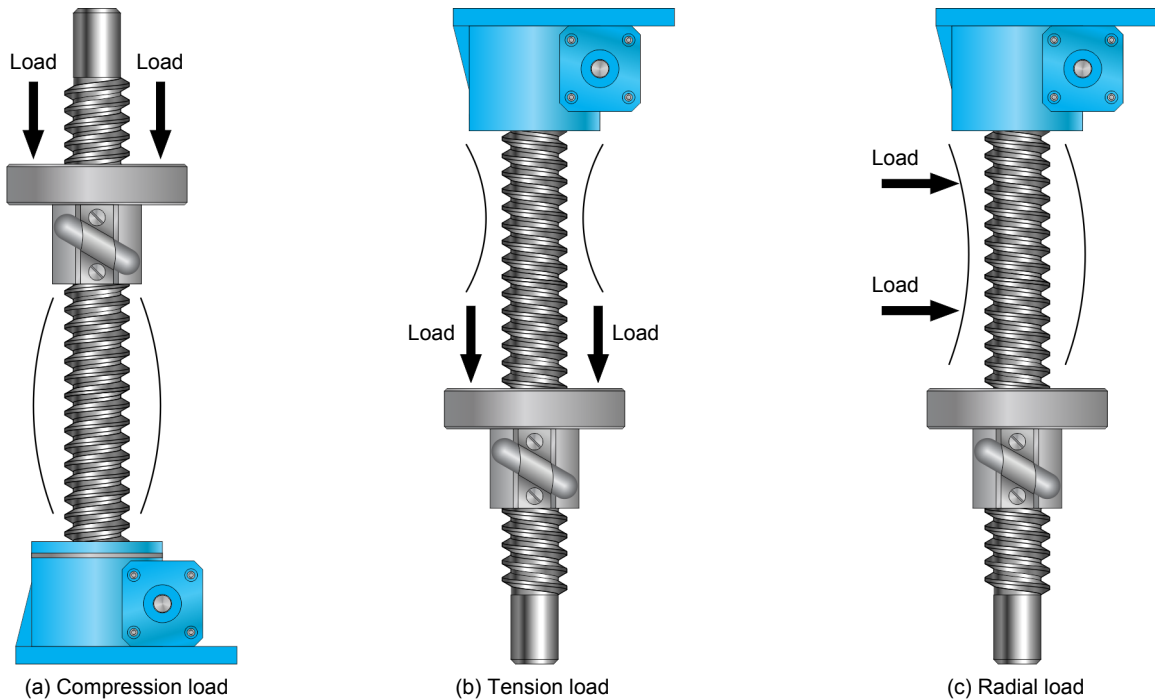

Figure 17. Types of load applied on a ball screw.

When installing a ball nut with a single return pipe, it is recommended to make sure the return pipe faces up or, at least, not down (laterally is acceptable), as shown in Figure 18a. However, when installing a ball nut with two return pipes, it is recommended that both return pipes face laterally, ensuring that no return pipe faces down, as shown in Figure 18b. Down-facing return pipes are usually avoided since gravity could prevent the proper return of the balls in the ball nut.

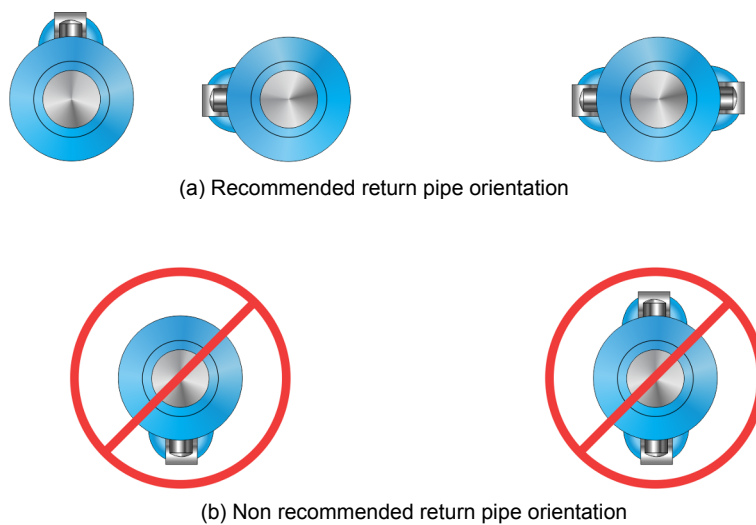

Figure 18. Orientation of return pipes during ball nut installation.



For storage purposes, ball nuts are usually mounted on an arbor, and maintained in place using retainers, as shown in Figure 19.

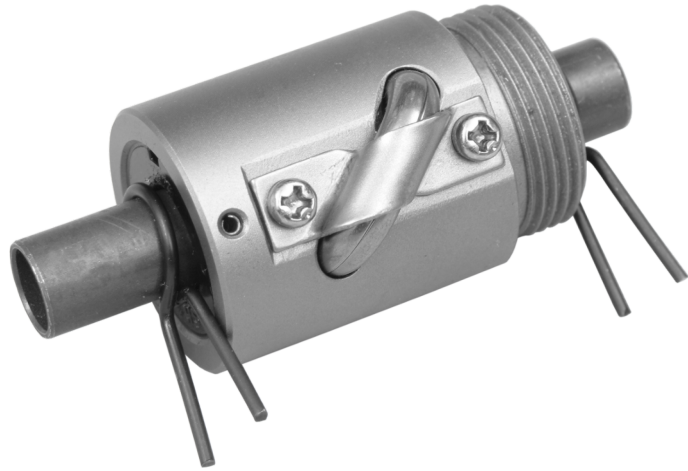

Figure 19. Ball nut mounted on an arbor for storage.

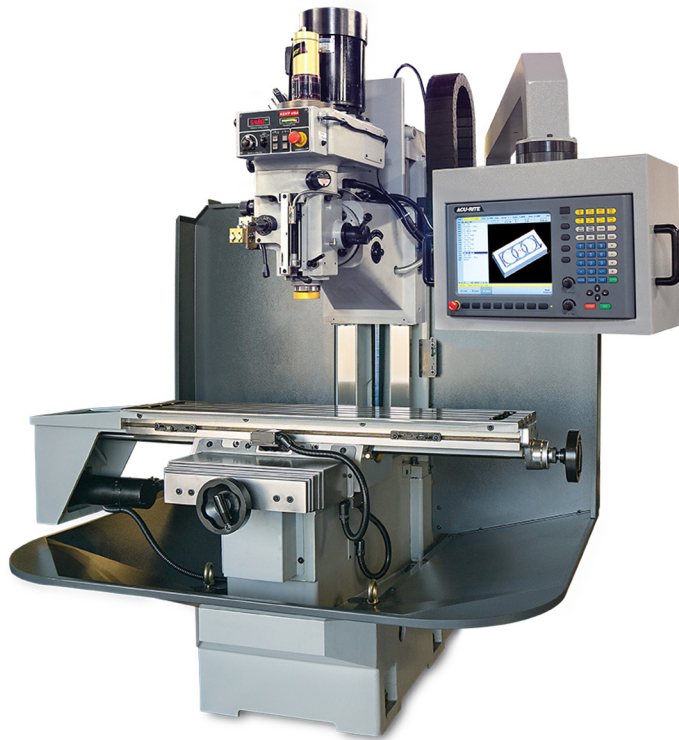

Figure 20. Linear bearings and ball screws are commonly used for horizontal and vertical movement in CNC mills.<sup>3</sup>

<sup>3</sup> Photo by Mike Zielinski, September 18, 2017 via Wikipedia:  
[https://commons.wikimedia.org/wiki/File:Kent\\_USA\\_CNC\\_Bed\\_Mill\\_TW-32Qi.jpg](https://commons.wikimedia.org/wiki/File:Kent_USA_CNC_Bed_Mill_TW-32Qi.jpg). Available under a Creative Commons Attribution-ShareAlike 4.0 International (CC BY-SA 4.0): <https://creativecommons.org/licenses/by-sa/4.0/>.

### **Maintenance and lubrication of ball screws and ball nuts**

As for linear bearings, the service life of a ball screw and its ball nut corresponds to the length of time the ball screw and nut remain operational under given operating conditions. The length of the service life depends on a multitude of factors, such as material fatigue due to the load, wear of the ball nut's recirculation system, wear of the ball screw's threads, corrosion, and lubrication intervals.

Signs indicating the near failure or failure of the ball screw and nut include:

- Excessive wear
- Pitting
- Gouges
- Corrosion
- Spalling
- Brinelling

The most important part of ball screw and nut maintenance is their lubrication and relubrication. Both oil and grease are commonly used. Oil lubrication is typically more complex and requires a pump and a filtering system. Grease, on the other hand, is normally not recommended for applications operating at low temperatures or at high speed. High-speed operation may also throw off lubricants, requiring a more adequate lubricant spread or more frequent lubrication.

The lubrication of a ball screw should occur at intervals regular enough to maintain a film of lubricant on the screw at all times. This ensures the frictionless and efficient operation of the ball screw. As for the ball nut, the balls can be lubricated during their insertion in the ball nut, or through the nut's grease fitting, if available.

Before lubricating a ball screw or ball nut, it is always recommended to consult the manufacturer's documentation for any additional advice.

## Ball Nuts and Ball Screws



*The results given in this job sheet are typical measurements. The actual results obtained by students vary.*

### OBJECTIVE

- Install a ball screw
- Slide a ball nut on a ball screw and on an arbor
- Disassemble a ball nut
- Assemble a ball nut on a ball screw
- Disassemble and reassemble a bearing housing

### PROCEDURE

#### Equipment required

Refer to the Equipment Utilization Chart in Appendix A to obtain the list of equipment required for this job.

#### Safety procedures

Before proceeding with this job, make sure to complete the following checklist.

- You are wearing safety glasses.
- You are wearing safety shoes.
- You are not wearing anything that might get caught such as a tie, jewelry, or loose clothes.
- If your hair is long, tie it out of the way.
- The working area is clean and free of oil.
- The floor is not wet.
- Your sleeves are rolled up.

#### Lockout/tagout procedure

Perform the lockout/tagout procedure described in Appendix B.

### Preliminary procedures for this job sheet

Before starting this job sheet, make sure you have performed the following procedures from Job Sheet 1:

- Setup
- Installing the linear ball bearings in the guides

Figure 21 shows the current equipment setup after the above procedures.

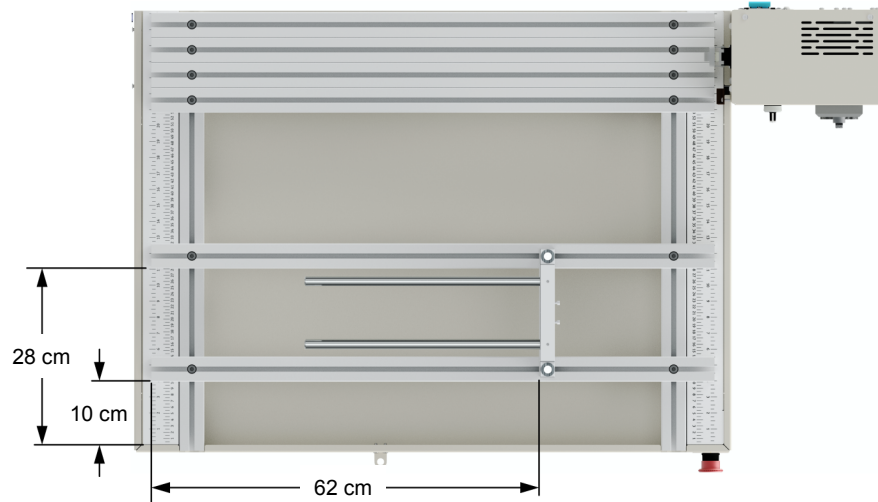

Figure 21. Current equipment setup.

### Installing the ball screw

1. Place a 29 cm riser on the two extrusions, about 10 cm from the tip of the shafts, as shown in Figure 22. Do not screw this riser in place. It is only used to support the ball screw and prevent any bending damage while you perform this job sheet.

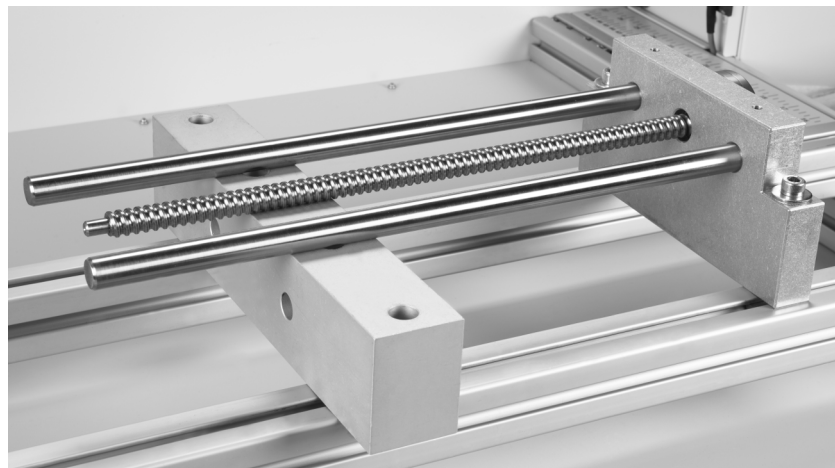

Figure 22. Ball screw with the supporting 29 cm riser.

2. Using the 3 mm hexagonal T-handle key, unscrew the four screws from the lateral face of the right ball screw base. Set them aside for the moment.
3. Take the ball screw from the Ball Screws and Linear Bearings 2 panel. Insert it from the right-hand side through the hole of the front ball screw base. Make sure the ball screw end without flange enters the base first. Push the ball screw as far as it can go and lay it on the 29 cm riser, as shown in Figure 22.
4. Align the empty screw holes of the ball screw flange with the screw holes in the front base. Using the 3 mm hexagonal T-handle key and the screws you set aside, screw the ball screw in place on the front base.
5. Take the handwheel from the Ball Screws and Linear Bearings 1 panel. Install it on the flange end of the ball screw, as shown in Figure 23. Push the handwheel as far as it can go. Using the 3 mm hexagonal T-handle key, tighten the handwheel setscrew against the flat surface of the ball screw tip.

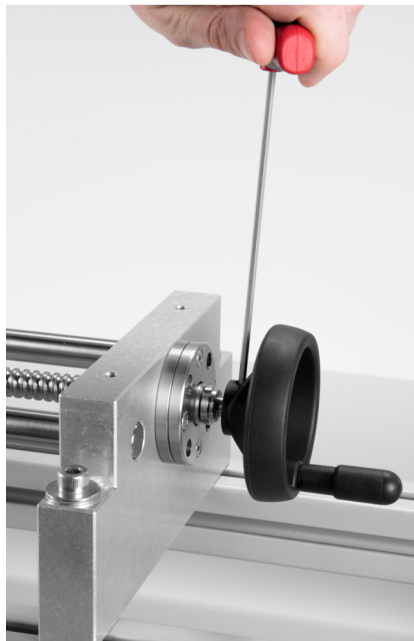

Figure 23. Installing the handwheel.

### Sliding the ball nut on the ball screw



*While performing the steps in this section, make sure that either the arbor or the ball screw is inserted in the ball nut at all times. Otherwise, the balls inside the nut will slide out. Inserting the balls back in the nut is a time-consuming process.*

6. On the ball nut, remove the locking pin from the arbor on the threaded side of the nut. Do not remove the arbor from the nut.

7. Press the tip without locking pin of the arbor on the free tip of the ball screw, as shown in Figure 24a. Make sure the tip of the ball screw inserts all the way inside the arbor.

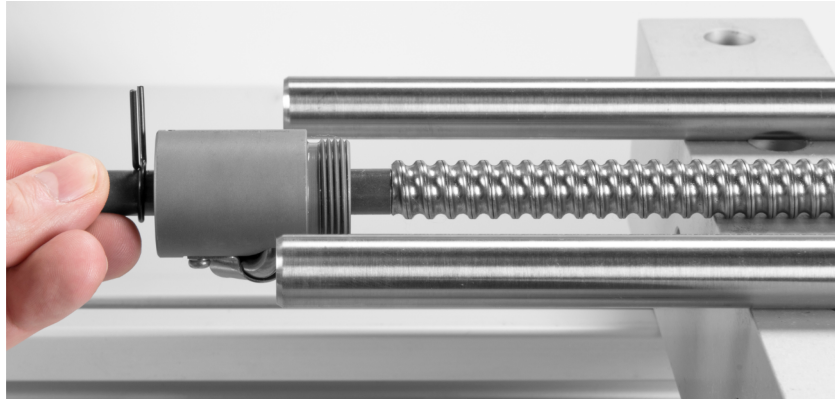

(a)



(b)

**Figure 24. Sliding the ball nut on the ball screw.**

8. Slide the nut on the ball screw. Screw the nut clockwise on the ball screw until no part of the nut protrudes on the arbor, as shown in Figure 24b. The nut should screw on the ball screw with little resistance.

### Sliding the ball nut on the arbor



*While performing the steps in this section, make sure that either the arbor or the ball screw is inserted in the ball nut at all times. Otherwise, the balls inside the nut will slide out. Inserting the balls back in the nut is a time-consuming process.*

9. Press the tip without locking pin of the arbor on the free tip of the ball screw, as shown in Figure 25a. Make sure the tip of the ball screw inserts all the way inside the arbor.



Figure 25. Sliding the ball nut on the arbor.

10. Screw the nut counterclockwise on the ball screw until the nut slides completely on the arbor, as shown in Figure 25b.
11. Install the removed locking pin on the side of the arbor without locking pin.

### Disassembling the ball nut

12. Place the ball nut in a large flat tray in order to prevent the loss of balls during disassembly.
13. Using the cruciform screwdriver, unscrew both screws of the return pipe holder on the ball nut, as shown in Figure 26. Remove the holder and set it aside in the tray for the moment.



Figure 26. Unscrewing the screws of the return pipe holder on the ball nut.

14. Remove the return pipe with your fingers, as shown in Figure 27. Separate both halves of the return pipe. Remove all balls inside it. Set the return pipe and balls aside in the tray for the moment.



Figure 27. Removing the return pipe.

15. Remove a locking pin from the arbor on any side of the ball nut. Then, remove the arbor. This allows the balls in the ball nut to be removed, as shown in Figure 28.



Figure 28. Removing the balls from the ball nut.

Using a pen, screwdriver, hexagonal key, or any small tool, push all balls off the ball nut. Set the balls aside in the tray for the moment.

💡 There should be 49 balls in the ball nut. Remove any extra balls or add balls until there are 49 balls.



### Installing the empty ball nut on the ball screw

16. Lay one half of the return pipe on a work surface. Then, place 11 balls on its interior surface, as shown in Figure 29.

 It may help the balls adhere to the return pipe if you slightly grease the interior of the pipe beforehand.



Figure 29. Filling one half of the return pipe with balls.

17. Slide the nut on the ball screw, with the threaded side going first. Screw the nut clockwise on the ball screw until it is about 15 cm from the tip. Make sure the ball holes face up.
18. One by one, insert all remaining balls (there should be 38) in the ball nut. Insert the balls in the slot closest to the free end of the ball screw, as shown in Figure 30. This is a delicate operation. In order to not have to restart from the beginning, do the following:
- Insert the balls one by one, making sure the balls land as directly as possible in the bottom hole of the slot.
  - Do not let any ball enter the lateral hole of the slot. This hole leads out of the circuit delimited by the return pipe. During movement, the ball would block against the thread stop at the end of the ball nut, locking it in place and damaging the threads.
  - After each ball lands in the slot, slightly rotate the ball screw in the counterclockwise direction, just enough to make way for another ball.
  - Do not rotate the ball screw counterclockwise too much, since this would create a gap between the balls. It would cause the balls to take too much space in the circuit and spill out of the other slot of the nut or, worse, continue out of the circuit delimited by the return pipe.
  - You can use a small tool, such as an arbor lock pin, to push against the balls already inserted in the slot. This could help reduce the gap between the balls. Do not push too heavily.



Figure 30. Inserting the balls in the ball nut.

19. Place the other half of the return pipe on the half containing the balls.

Insert the return pipe inside the ball holes of the ball nut, as shown in Figure 31. While doing so, make sure to maintain the return pipe almost horizontal to prevent the balls from sliding off of the return pipe.

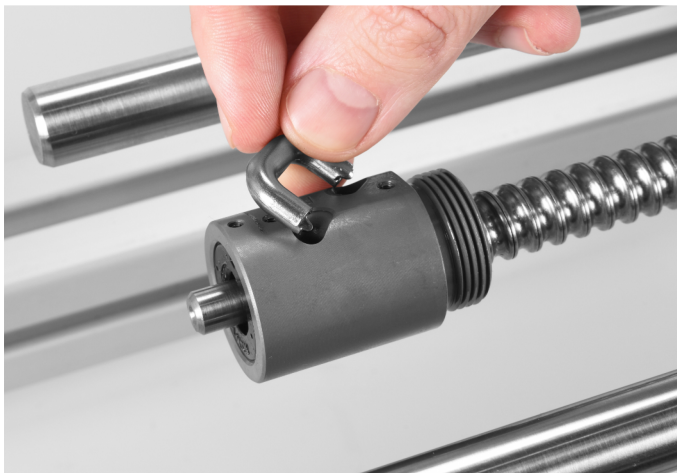

Figure 31. Inserting the return pipe inside the ball holes of the ball nut.

20. Place the return pipe holder on the pipe. Using the cruciform screwdriver, screw both screws of the holder on the ball nut.
21. Slowly rotate the ball nut back and forth on the ball screw.

**CAUTION**

If you encounter resistance at any point during the rotation of the ball nut around the ball screw, stop immediately. A ball is probably out of the circuit delimited by the return pipe. Trying to rotate further could damage the ball nut or screw.

If the ball nut does not rotate perfectly around the ball screw, it is recommended to remove the ball nut (taking care not to lose balls) place the ball nut in the flat tray, and return to step 13 of this job sheet.

- 22.** The ball nut is now installed on the ball screw. Ask the instructor to check your work.
- 23.** Perform the Sliding the ball nut on the arbor section in this job sheet to remove the ball nut from the ball screw.

### **Disassembling the bearing housing**

- 24.** Take the HN0 wrench from the Ball Screws and Linear Bearings 1 panel. While holding the handwheel with your hand, use the HN0 wrench to rotate the lock nut beside the ball screw flange counterclockwise, as shown in Figure 32. Rotate the lock nut as much as possible.

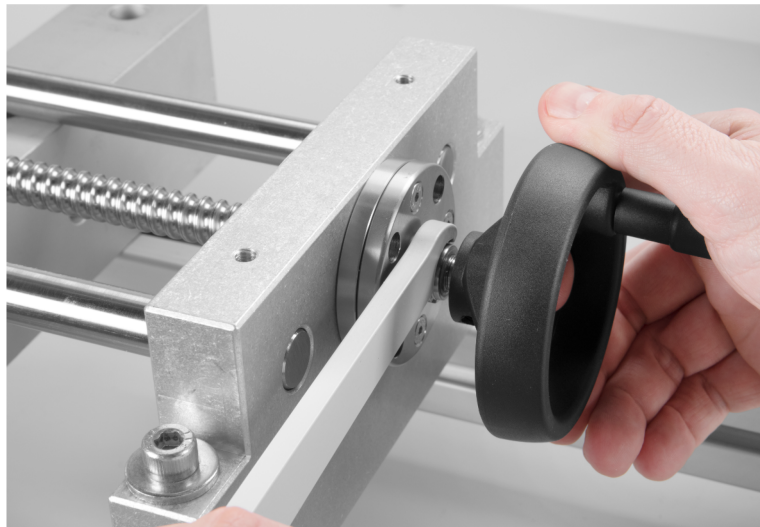

**Figure 32.** Removing the lock nut using the HN0 wrench.

- 25.** Using the 3 mm hexagonal T-handle key, release the handwheel setscrew. Remove the handwheel and set it aside for the moment.
- 26.** Continue rotating the lock nut counterclockwise until you can remove it from the ball screw with your hands. Set the lock nut aside for the moment.

- 27.** Remove the spacer from the center of the flange with your fingers, as shown in Figure 33. Set it aside for the moment.



**Figure 33.** Removing the spacer from the center of the flange.

- 28.** Remove the cover of the flange by unscrewing the four screws using the appropriate hexagonal key. Remove the flange cover and set it aside for the moment.

 The screws holding the flange cover on the flange base have 2.5 mm hexagonal screw holes, while the screws holding the ball screws on the front base have 3 mm hexagonal screw holes. Do not mistake one for the other.

- 29.** Remove the two angular contact ball bearings. To do so, push on the ball screw so that it slides toward the right, as shown in Figure 34. This pushes the two angular contact ball bearings out from the flange base. Remove the bearings from the ball screw and set them aside for the moment.



**Figure 34.** Removing the two angular contact bearings.

30. The bearing housing is now fully disassembled. Ask the instructor to check your work.

### Assembling the bearing housing

31. Observe the angular contact ball bearings. Notice that both sides of each bearing are not identical. On one side, the inner shoulder of the bearings is wide, while on the other side, it is narrow, as shown in Figure 35. The orientation of each bearing is important, as it can only support axial loads from one side. Therefore, to support axial loads from both sides, the two angular contact ball bearings must be mounted opposite to each other.

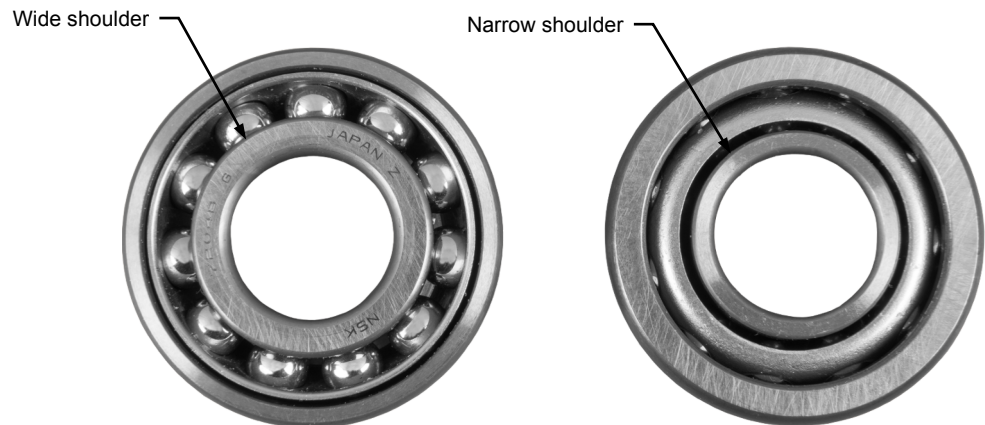



Figure 35. Angular contact ball bearings.

32. Install the angular contact ball bearings on the flange end of the ball screw in a face-to-face configuration (i.e., with their narrow shoulders facing each other). Push the bearings all the way inside the flange base, as shown in Figure 36.

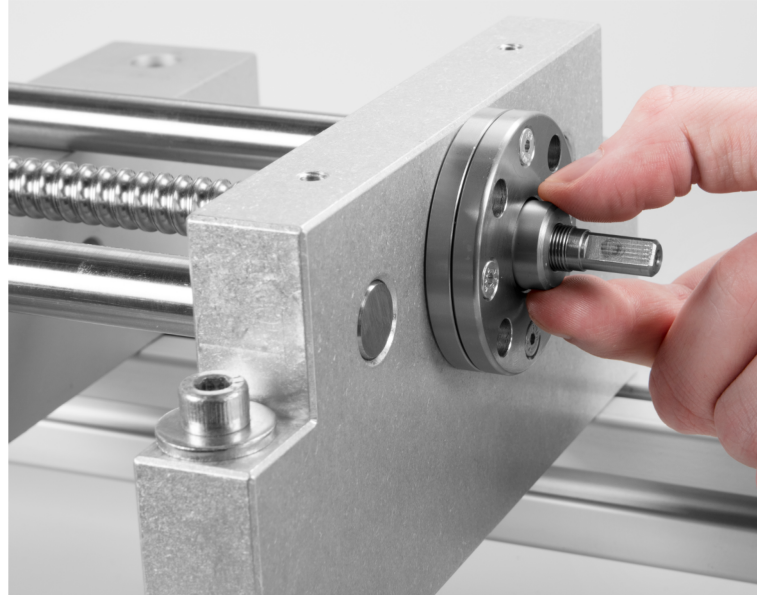

Figure 36. Inserting the angular contact ball bearings in the flange base.

- 33.** Locate the flange cover and its corresponding screws. Install the flange cover on the flange base. Make sure the tapered screw holes of the flange cover align with the empty screw holes of the flange base. Screw the four screws in the screw holes.

 The screws holding the flange cover on the flange base have 2.5 mm hexagonal screw holes, while the screws holding the ball screws on the front base have 3 mm hexagonal screw holes. Do not mistake one for the other.

- 34.** Locate the spacer. Slide it on the flange end of the ball screw and insert it completely inside the flange cover, as shown in Figure 37.



**Figure 37.** Inserting the spacer inside the flange cover.

- 35.** Locate the lock nut. Slide it on the flange end of the ball screw and screw it as much as possible with your hands.

- 36.** Locate the handwheel. Install it on the flange end of the ball screw, as shown in Figure 38. Push the handwheel as far as it can go. Using the 3 mm hexagonal T-handle key, tighten the handwheel setscrew against the flat surface of the ball screw tip.

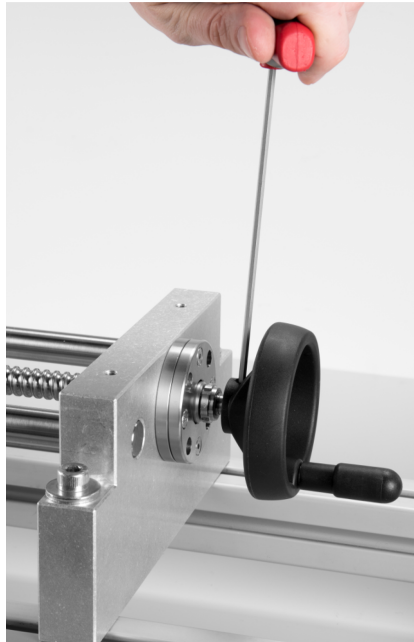

**Figure 38.** Installing the handwheel.

- 37.** Take the HN0 wrench from the Ball Screws and Linear Bearings 1 panel. While holding the handwheel with your hand, use the HN0 wrench to rotate the lock nut clockwise. Tighten the lock nut as much as possible on the spacer.
- 38.** The bearing housing is now fully reassembled. Ask the instructor to check your work.

### **Ending the job sheet**

- 39.** Part of the equipment is currently installed to perform the next job sheet. If you wish to do so, proceed directly to the next job sheet.

If not, disassemble the setup and return the components to the storage location.

Name: \_\_\_\_\_ Date: \_\_\_\_\_

Instructor's approval: \_\_\_\_\_